



Feature:

- Mounts easy on round & square shaft (with option -8).
- External clutch for manual adjustments.
- Maintenance free.
- Position indicator.
- Fail safe by *Enerdrive System*¹
- Auxiliary switches (on model 80S).

Old number

<i>MDTS1060</i>	DT060S
<i>MDTS1065</i>	DT065S
<i>MDTS1080</i>	DT080S
	DT160S
	DT165S
	DT180S
	DT260S
	DT265S
	DT280S

Technical Data	DT060S <i>MDTS1060</i>	DT065S <i>MDTS1065</i>	DT080S <i>MDTS1080</i>	DT160S	DT165S	DT180S	DT260S	DT265S	DT280S
Auxiliary switches	No	No	Yes (2)	No	No	Yes (2)	No	No	Yes (2)
Feedback	No	Yes	No	No	Yes	No	No	Yes	No
Power supply	22 to 26 VAC or 28 to 32 VDC			110 to 130 VAC 50/60Hz			220 to 250 VAC 50/60Hz		
Power consumption	15VA Peak, 6VA			12VA Peak, 6VA					
Control signal	2 wire / 2 position, 4 wire / 3 point floating			3 wire / 2 position, 4 wire / 3 point floating					
Torque	50 in.lb. [5,6 Nm] at rated voltage (Fail-safe 35 in.lb. [3,9 Nm])			35 in.lb. [4 Nm] at rated voltage					
Running time through 90°	90 - 110 sec, (Fail-safe 70-80 sec)			90 - 110 sec, (Fail-safe 25-50 sec)					
Ingress protection	IP22 equivalent to Nema type 2, IP54 equivalent to Nema type 3R if water tight inlet bushings (not supplied NEP617) are installed			IP22 equivalent to Nema type 2					
Approvals				 Class 2					
Fail safe - Enerdrive	Yes								
Electrical connection	18 AWG [0.8 mm ²] minimum								
Inlet bushing	2 inlet bushing of 5/8 in [15.9 mm] & 7/8 in [22.2 mm]								
Angle of rotation	0 to 90 degrees, mechanically adjustable (factory set with 90° stroke)								
Direction of rotation	Reversible, Clockwise (CW) or Counterclockwise (CCW) (factory set with CW direction)								
Ambient temperature	-22°F to +122°F [-30°C to +50°C]								
Storage temperature	-22°F to +122°F [-30°C to +50°C]								
Relative Humidity	5 to 95 % non condensing.								
Weight	3 lbs. [1.4 kg]								

Warning: Do not press the clutch when actuator is powered

Dimensions

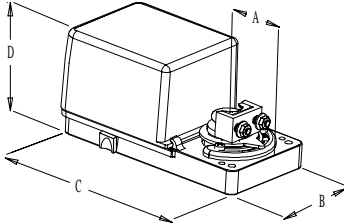

Dimension	Inches	Metric (mm)
A	1.50	38.1
B	3.26	82.8
C	6.60	167.5
D	model 0XX	76.4
	model 1XX & 2XX	94.5

Caution

We strongly recommend that all neptronic® products be wired to a separate transformer and that transformer shall service only neptronic® products. This precaution will prevent interference with, and/or possible damage to incompatible equipment.
When multiple actuators are wired on a single transformer, polarity must be observed. Long wiring runs create voltage drop which may affect the actuator performance.

¹ Enerdrive System U.S.A. Patent #5,278,454



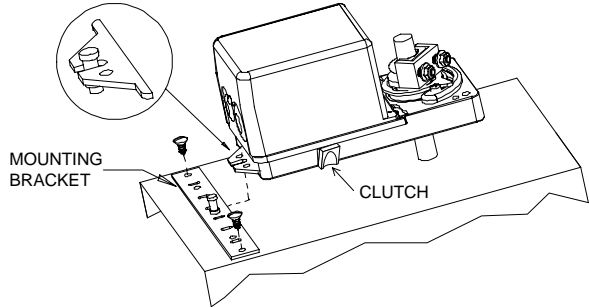

Mechanical installation

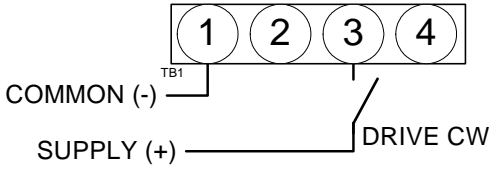
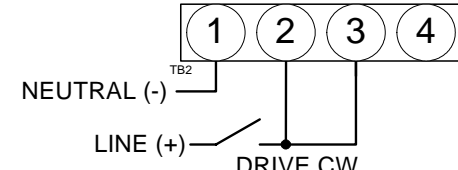
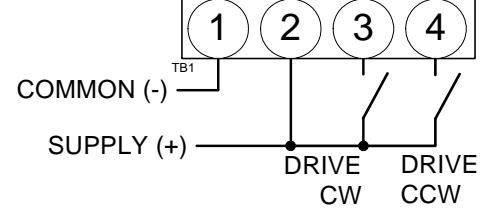
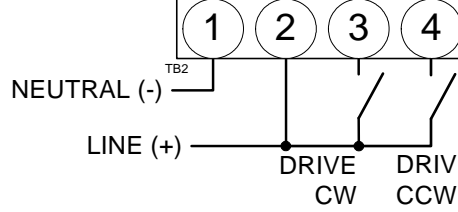
	<ol style="list-style-type: none"> 1. Manually close the damper blades and positioned the actuator at 0° or 90°. 2. Slide the actuator onto the shaft. 3. Tighten the nuts on the “U” bolt to the shaft with a 8mm wrench to a torque of 60 in.lb. [6,7 Nm]. 4. Slide the mounting bracket under the actuator. Ensure free movement of the slot at the base of the actuator. The bracket pin must be placed in the mid distance of the slot. 5. Fix the bracket to the ductwork with #8 self-tapping screws.
---	---

Wiring Diagrams

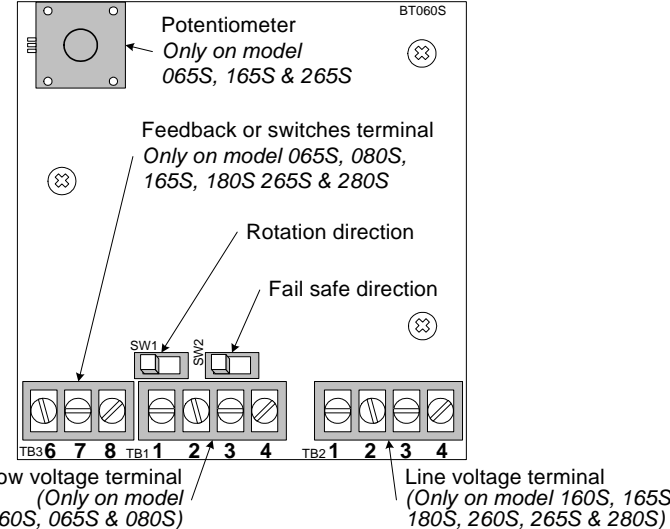
<p>Models DT060S, 065S & 080S</p>	<p>Models DT160S, 165S, 180S, 260S, 265S & 280S</p> <p>Caution: Risk of electric shock. Remove power prior to connect.</p>
<p>2 wire / 2 position (ON-OFF)</p> 	<p>3 wire / 2 position (ON-OFF)</p> 
<p>4 wire / 3 point floating</p> 	<p>4 wire / 3 point floating</p> 

PC Board

	<p>Dip switch settings</p> <p>Rotation direction (SW1)</p> <p>CW (0 to 90°)  CCW (90 to 0°) </p> <hr style="border-top: 1px dashed black;"/> <p>Fail safe direction (SW2)</p> <p>Fail safe return at 0°  Fail safe return at 90° </p>
---	---

Stroke adjustment

To adjust the stroke, move the adjustment screws at the desired position.