

THREE PORT VALVES

Specification No. MB – 617-X-XXX*
MBF – 618-X-XXX*

MB and MBF valves are of the 3-port rotary-shoe type. They are characterised for use as mixing or diverting valves, with hot or chilled water, in heating, ventilating and air conditioning applications.

The MB is driven by either the 'R' (DS 3.1) or 'AR' (DS 3.17) range of actuators. The MBF is only suitable for use with the 'AR' (DS 3.17) range of actuators.

Note: They will operate satisfactorily as two-port valves if the bottom port is blanked off.

The MB and MBF ranges of valves fitted with appropriate Satchwell actuators will fully comply with all relevant European directives.

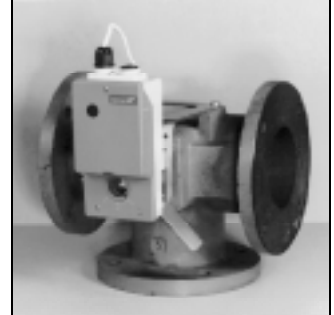
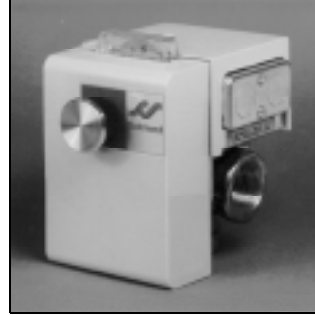

* For full specification number replace the 4Xs with the appropriate figures from the TYPE column in the table on Page 2.



SPECIFICATIONS

Group	Size	Kv or Cv	Type	Maximum Differential Pressure		Temperature Limits		Maximum Internal Pressure (gauge)		International Pressure Rating
				ARX 2201 ARM 2601 ARE 2301	XRM 3201 RM 3601 ARX 2251 ARM 2651 ARE 2351	Min.	Max.	kPa	lbf/in ²	
				kPa	kPa					
MB Screwed B.S.P. Parallel Female	½"	1.8	MB 1402	–	70	2°C	120°C	1000	145	PN 10 (ND 10)
	¾"	4.0	MB 1452	–	70					
	1"	8.0	MB 1502	–	70					
	1¼"	12.0	MB 1552	–	35					
	1½"	20.0	MB 1602	–	35					
2"	32.0	MB 1652	–	35						
MBF Flanged	65mm	63	MBF 4732	35	–	2°C	120°C	600	87	PN 6 (ND 6 TO DIN 2401)
	80mm	80	MBF 4782	25	–					
	100mm	120	MBF 4857	25	–					

100kPa = 1 Bar approximately equal to 1.02 kgf/cm² approximately equal to 14.5 lbf/in²

* Cv_s = Flow in UK gal/min to produce 1 lbf/in² pressure drop when the valve is fully open
Kv_s = Flow in m³/hr to produce 1 bar pressure drop when the valve is fully open

For full TECHNICAL SPECIFICATION see table on Page 3 which gives details of flange drilling, materials etc.

POSSIBLE ACTUATOR VALVE COMBINATIONS AND LINKAGES

ACTUATOR TYPE		'R' (See Data Sheet)	'AR' 15Nm (See Data Sheet)	'AR' 8Nm (See Data Sheet)
220 to 240Vac		RM (DS 3.1)	ARM (DS 3.17)	ARM (DS 3.15)
24Vac		XRM (DS 3.1)	ARX (DS 3.17)	AEX (DS 3.15)
0-10V Signal		–	ARE (DS 3.17)	ARE (DS 3.15)
Angular Stroke		90°∠	90°∠	90°∠
VALVE	MB ½" to 2"	Direct Coupling to valve - no linkage required. Not suitable for cooling applications.	No	Use linkage kit No. 826-2-702 (see DS 5.81)
	MBF 4732, 4782, 4857	No	Use linkage kit no. 826-2-701 (see DS 5.81). The kit is also used for converting other MBF specifications (see DS 5.81). Manual operating lever included (optional).	No

CONSTRUCTION AND TECHNICAL SPECIFICATION

TECHNICAL SPECIFICATION		MB ½ - 1"	MB 1¼"	MB 1½ & 2"	MBF 65 to 100mm
Pipe Connections	Screwed Parallel (female) BSP to BS 21 Flanged BS 4504, Table 6/11 (Equivalent to DIN 2531/ND6 and drilled to DIN 2501, ND6)	● —	● —	● —	— ●
Characteristic	Port 2 Modified Parabolic Port 3 Linear	● ●	● ●	● ●	● ●
Rangeability	50:1	●	●	●	●
Let-by	<0.5% (max) (% of Cv or % of Kv)	●	●	●	●
Temperature Working Pressure Test Pressure	See Table on Page 2 See Table on Page 2 2100 kPa (300 lbf/in ²)	● ● ●	● ● ●	● ● ●	● ● ●

MATERIAL

Body	Hot Pressed Brass to BS 218 Close Grained Cast Iron BS 1452 Grade 260 Close Grained Cast Iron to BS 1452 Grade 260 or 220	● — —	— ● —	— ● —	— — ●
Valve Plate Assembly	Stainless Steel to BS 1449 1967 Grade 301S21 Bonnet: Brass to BS 2874 CZ131	●	●	●	—
	Cast Iron Plate to BS 1452 Grade 260 or 220 Gland Housing Brass to BS 2874 CZ122	—	—	—	●
Sleeve	Aluminium Brass Alloy to BS 2870 CZ110 or Arsenical Brass to BS 2875 CZ105 or Gilding Brass to BS 2870 CZ102	—	●	●	●
Shoe	PTFE Filled Sintered Shoe	●	●	●	●
	Driving Plate Brass to BS 2873 CZ108	—	●	●	●
Spindle	High Tensile Brass to BS 2874 CZ114	●	●	●	●
End Bearing	As body material Brass to BS 2873 CZ108	● —	— ●	— ●	— —
	Stainless Steel to BS 970 Grade 321S12	—	—	—	●
'O' Rings	Adjacent to control medium: Ethylene Propylene Adjacent to air: Ethylene Propylene	● ●	● ●	● ●	● —
Springs	Stainless Steel to BS 970 Grade 302S25	●	●	●	●

SPARES

Reconditioning kits	617-9-410 617-9-411 617-9-412 617-9-413	● — — —	— ● — —	— — 1½" 2"	— — — —
Reconditioning kits	618-9-510 618-9-511 618-9-512	— — —	— — —	— — —	65mm 80mm 100mm

PACKED WEIGHTS

MB ½"	1.1 kg	MBF — 65mm	17.0 kg
MB ¾"	0.9 kg	MBF — 80mm	25.5 kg
MB 1"	1.1 kg	MBF — 100mm	30.0 kg
MB 1¼"	2.1 kg		
MB 1½"	3.1 kg		
MB 2"	3.9 kg		

GOOD DESIGN PRACTICE

Control Medium

These valves are designed for use with hot water in a closed circuit.

They may also be used with brine (up to 15% NaCl or CaCl solution) or Glycol solution (25% max) for freeze protection with appropriate corrosion inhibitors. (See Construction Materials in table on Page 3).

Other fluids - e.g. seawater, oils etc.: Satchwell cannot accept responsibility for use of these valves with fluids other than those listed above. Detailed specifications of all materials in contact with the fluid are given in Table on Page 3 and it is the responsibility of the specifier to check their suitability.

The valves are intended to be used in closed circuits for water; if the circuit is open e.g. mains water it is possible that a build-up of mineral deposits may impair the operation of the valve and frequent maintenance will be necessary. Appropriate precautions should be taken.

The valve should have an authority of approximately 0.5. That is, the pressure drop through the valve should be as near as practicable equal to the pressure drop through the rest of the circuit which it controls.

It is suggested that strainers should be fitted to protect the valves. When strainers are fitted the following recommendations should be observed:-

- Strainers bodies for line sizes up to DN 50 (50mm) should be Bronze to BS 1400, PB1 or cast iron to BS 1452, class 180.
- Strainer pressure ratings should be at least 150% of the maximum pressure expected in the application.
- Strainer screens should be of a suitable stainless steel construction.
- The strainer screen should have a free area at least 250% of the line cross sectional area.
- The screen perforation diameter should be in the range of 0.7 to 0.9mm for sizes up to DN 50 (50mm).
- The screen perforation diameter should be in the range of 1.5 to 1.8mm for sizes over DN 50 (50mm).
- Strainers should be installed in parallel to enable online maintenance to be carried out.

WATER SIZING CHARTS ARE GIVEN IN DATA SHEET V110

INSTALLATION

The system should be thoroughly flushed out to remove foreign matter before fitting the valve. The fitting of strainers is not a substitute for flushing the system out fully. Failure to fully flush the system can result in frequent clogging of the strainers.

1. Select location for valve which is reasonably clean with adequate access for fitting and wiring actuator.
2. Ambient temperature limits:
MB with 'R' actuator:
0 to 50°C - for water up to 80°C
0 to 35°C - for water up to 120°C
(pro rata in between)
MB, MBF with ARE, ARM or ARX actuator, -20 to 50°C
3. Ensure that when installed the RM or XRM actuator shaft is horizontal, and that at least one port is vertical. When using ARX, ARM or ARE Actuators they may be mounted in any position as long as they are not underneath the valve. For chilled water applications use 'AR' type actuator with appropriate linkage.

The flow may be in either direction through the valve. The marking cast on the body indicates the internal configuration. Port 1 is always common. Port 2 is open for full load. Port 3 is open for full by-pass (zero load). See Fig.1 to Fig.4.

Allow sufficient access for linkage, actuator and wiring.

4. Install the valve as follows:
 - a. Remove all protective materials from the valve.
 - b. The system should be thoroughly flushed out to remove foreign matter before fitting the valve.
 - c. Fit valve into pipework using the minimum quantity of jointing materials.

MAINTENANCE

ISOLATE VALVE CONTROL MEDIUM AND RELIEVE PRESSURE BEFORE REMOVING THE ACTUATOR OR WORKING ON THE VALVE.

A periodic check of the valve should be made for general condition and leakage. For replacement gland kits etc. see table on Page 3.

Mixing

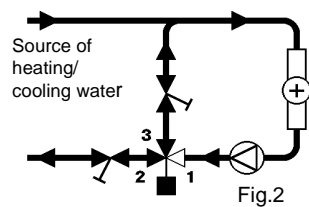
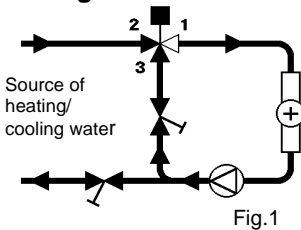

Diverting

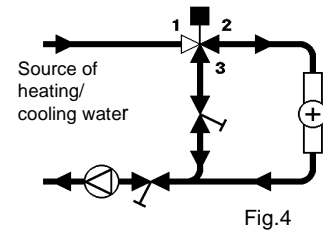
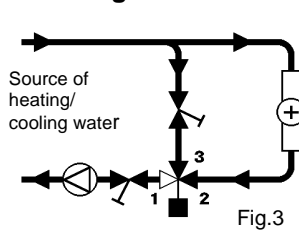

DIMENSION DRAWINGS

MB

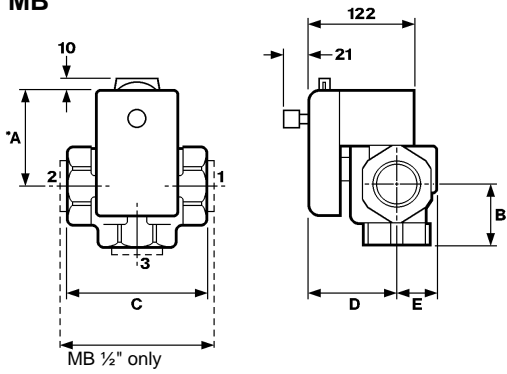

RM, XRM

Valve Size	*A mm	B mm	C mm	D mm	E mm
1/2"	86	55	110	77	24+
3/4"	86	45	91	77	24+
1"	86	47	94	77	24+
1 1/4"	90	49	115	85	30
1 1/2"	94	52	134	104	49
2"	100	63	148	104	49

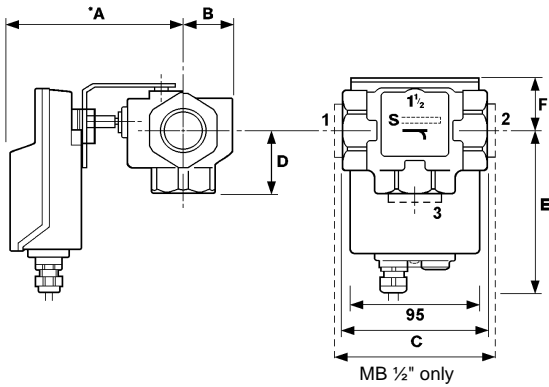

ARM 2651, ARX 2251, ARE 2351

Valve Size	*A mm	B mm	C mm	D mm	E mm	F mm
1/2"	117	24	110	55	175	43
3/4"	117	24	90	45	175	43
1"	117	24	94	47	175	43
1 1/4"	123	30	115	50	170	48
1 1/2"	142	49	134	53	167	51
2"	142	49	148	64	160	58

* Access and fitting clearance: allow additional 150mm to dimension A

All dimensions in mm

MBF

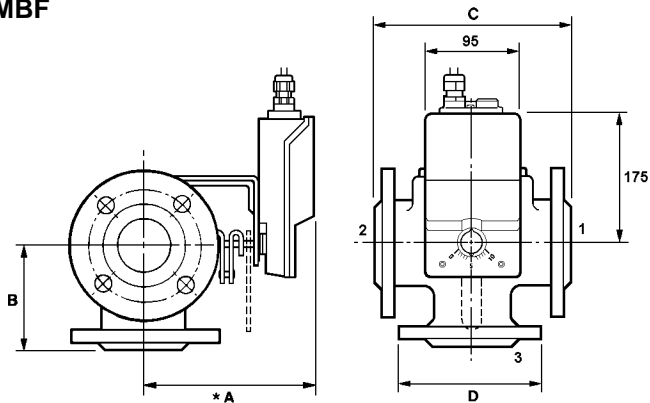

ARM 2601, ARX 2201, ARE 2301

Valve Size	*A mm	B mm	C mm	D mm
65mm	169	114	226	160
80mm	202	129	254	190
100mm	202	150	297	210

* Access and fitting clearance: allow additional 150mm to dimension A



Satchwell Control Systems Limited
Farnham Road
Slough
Berkshire SL1 4UH
United Kingdom

Telephone +44 (0)1753 550550
Facsimile +44 (0)1753 824078

A Siebe Group Company

CAUTION

- Observe recommendation under 'Good Design Practice' - see Page 4.
- **ISOLATE VALVE CONTROL MEDIUM AND RELIEVE PRESSURE BEFORE REMOVING THE ACTUATOR OR WORKING ON THE VALVE.**
- The system should be thoroughly flushed out to remove foreign matter before fitting the valve.
- Observe limits of water temperature, system pressure and maximum differential pressure - see Page 2.
- Interference with parts under sealed covers renders the guarantee void.
- Information is given for guidance only and Satchwell do not accept responsibility for the selection or installation of its products unless information has been given by the Company in writing relating to a specific application.
- Design and performance of satchwell equipment are subject to continual improvement and therefore liable to alteration without notice.
- A periodic system and tuning check of the control system is recommended. Please contact your local Satchwell service office for details.